

المركز السعودي للتحكيم
Saudi Arbitration Center



دليل الهوية
Brand Guideline

INDEX

Title	Page No.
1. Corporate Logo	3
1.2. Usage - Acceptable Versions	5
1.3. Usage - Unacceptable Versions	6
1.4. Margin Allowance	7
1.5. Minimum Size Requirements	8
1.6. Color Palette	9
1.7. Corporate Typography - Arabic	10
1.7.1. Corporate Typography - English	11
1.7.2. System Typography - Digital Communication	12
1.7.3. Typography Usage - Offset Print	13
1.7.4. Typography Usage - Online & MS Word	14
2. Standard Paper Sizes	16
2.1. Letterhead	17
2.1.1. Letterhead front - Technical Information	18
2.1.2. Letterhead MS Word - Arabic	19
2.1.3. Letterhead MS Word - English	20
2.2. Continuation Sheet	21
2.3. Business Card	23
2.4. Identity Card	25
2.5. Envelope Specification	28
2.6. DL Envelope	29
2.7. A4 Envelope	31
2.9. A4 Folder	33

1. CORPORATE LOGO

FULL COLOR MASTER LOGO SAMPLE

المركز السعودي للتحكيم
Saudi Arbitration Center



The Saudi Arbitration Center logo should always be reproduced exactly as specified in these guidelines and must be maintained exactly as it appears in the approved artwork and must not be altered or recreated in any way unless absolutely necessary. We have provided guidelines on proportions in case you are supplied with a logo which has been altered or tampered with.

1. CORPORATE LOGO

FULL COLOR MASTER LOGO - TECHNICAL INFORMATION

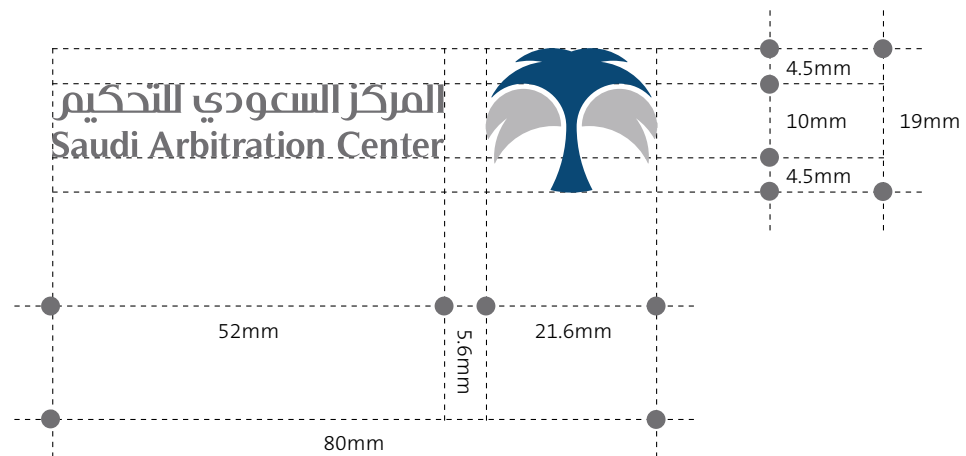

Wherever possible, please avoid recreating the logo. However in the absence of original artwork the above diagram provides strict guidelines on the specification of the logo.

Size : The above example shows the assembly of a 70x41.8mm logo. Use these dimensions to create the logo in illustrator and then resize proportionately up or down.

Colors : Saudi Arbitration Center color. Please refer section 1.6.

Note : Above specification is not actual size. Do not take measurement off this image.

1.2. USAGE - ACCEPTABLE VERSIONS



The logo can be used in horizontal format. When placing the logo on a color background, five options exist.

- Option 1 : White background. In this case the full color logo should always be used. i.e. Saudi Arbitration Center color logo.
- Option 2 : Saudi Arbitration Blue. In this case the White color logo needs to be used.
- Option 3 : Saudi Arbitration Gray. In this case the White color logo needs to be used.
- Option 4 : Saudi Arbitration Black. In this case the White color logo needs to be used.
- Option 5 : Saudi Arbitration Center white background. In this case only the one color combination to be used.

An exception to this logo application is when it needs to be placed on a vehicle with a color background. If the color has a dark tone, eg Dark Green and Light Green, then the white version of the logo is to be applied.

1.3. USAGE - UNACCEPTABLE VERSIONS

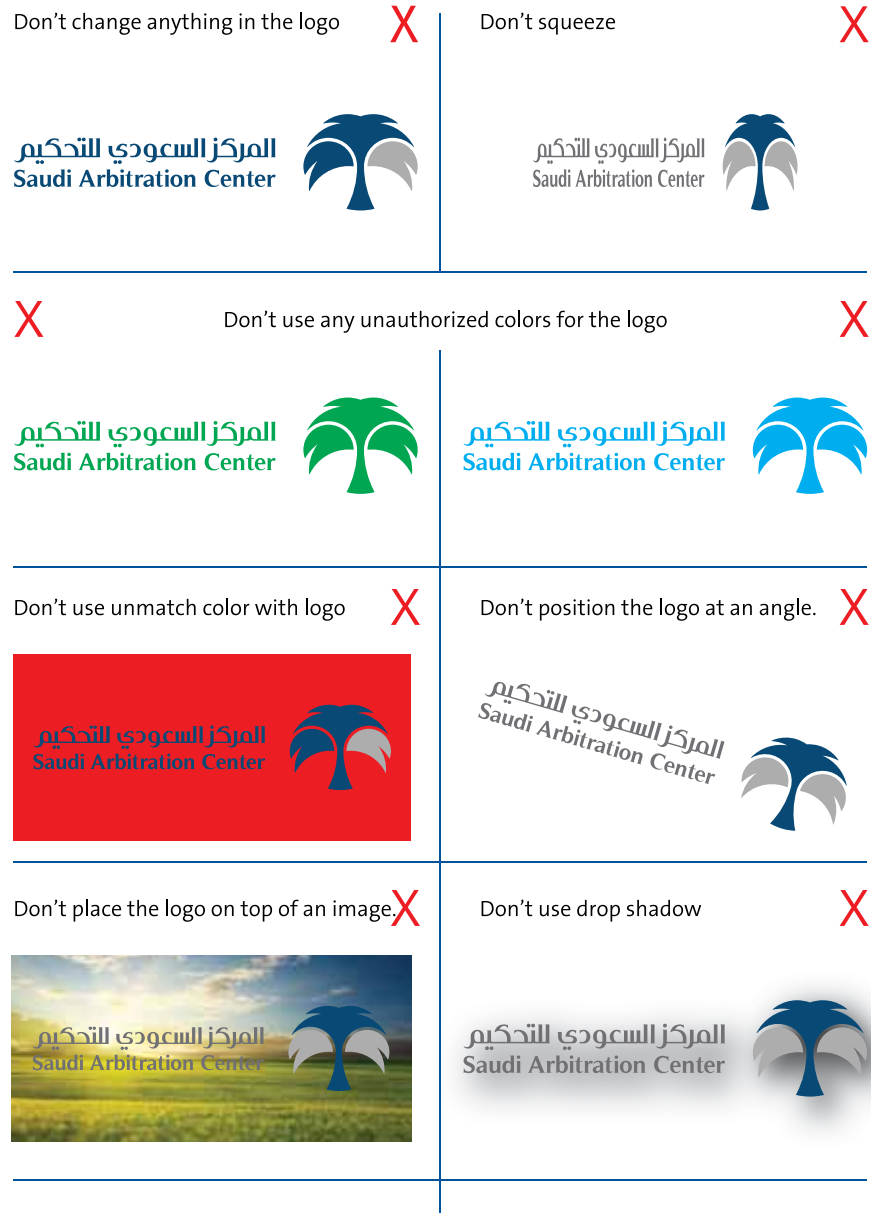

This section covers all the instances where the logo may not be applied.

1. Never adjust the spacing or color to the text of the logo.
2. Never squash the logo or change it's proportions.
4. Never use the logo in one color i. e. green or cyan.
3. Never place the full color logo on any background. i.e. Saudi Arbitration Center Logo.
5. Never position the logo at an angle. Always horizontal.
6. Never place the logo on top of an image.
7. Never apply a drop shadow to the logo.

1.4. MARGIN ALLOWANCE



The above illustration shows how to determine the amount of “free space” which has to be provided around the logo. Once you have determined the size of logo you plan to use in the application, use itself as the template to measure the box. This area may not carry any other logos, images, text or parts thereof in it.

The logo must appear in uncluttered space free of taglines, logotypes, shapes and strong background patterns. Always surround the logo with sufficient free space, which at a minimum, must equal the area of the graphic in the logo.

Exception : When applying the logo in large format (outdoor) branding such as a banner, a smaller margin allowance acceptable.

1.5. MINIMUM SIZE REQUIREMENTS

MINIMUM SIZE FOR PRINT USAGE (Including MS Word Format)



MINIMUM SIZE FOR WEB USAGE / ONLINE



MINIMUM SIZE FOR OUTDOOR USAGE



The above illustrations show what minimum size (width) can be used for Print (mm), Web (pixels) and Outdoor (cm) applications. Use of the logo below these minimum specs will result in sub-standard re-production and limited legibility.

1.6. COLOR PALETTE

PRIMARY COLORS



PANTONE 7693 C

CMYK: C100 | M73 | Y30 | K14

RGB Color: R0 | G72 | B118



PANTONE Cool Gray 11 C

CMYK: C0 | M0 | Y0 | K68

RGB Color: R113 | G112 | B115

SECONDARY COLORS



Black

CMYK: C0 | M0 | Y0 | K100

RGB Color: R0 | G0 | B0

Saudi Arbitration Center has its own distinctive palette of corporate colors.

The two colors represented above in two color mix formats namely, CMYK, RGB should give any designer the correct tools to ensure the right color in their applications.

Please use only these four colors when preparing any collateral or design work. There are six primary colors which are to be used for major coloring and one secondary colors which should be used for fill in applications and fonts (black). In some cases, 60% Black may be required as a major color such as a TheSans B3 Light I holder. This is acceptable as the material used is silver and not colored silver. For example a silver folder printed in silver would be unacceptable.

1.7. CORPORATE TYPOGRAPHY - ARABIC

RECOMMENDED ARABIC TYPEFACE FOR SAUDI ARBITRATION CENTER

GE Thameen - light

أ ب ت ث ج ح خ د ذ ر ز س ش ص ض ط ظ ع غ ف ق ك ل م ن ه و ي
٩ ٨ ٧ ٦ ٥ ٤ ٣ ٢ ١ ٠

GE Thameen - demi bold

أ ب ت ث ج ح خ د ذ ر ز س ش ص ض ط ظ ع غ ف ق ك ل م ن ه و ي
٩ ٨ ٧ ٦ ٥ ٤ ٣ ٢ ١ ٠

HacenLinerXL

أ ب ت ث ج ح خ د ذ ر ز س ش ص ض ط ظ ع غ ف ق ك ل م ن ه و ي
٩ ٨ ٧ ٦ ٥ ٤ ٣ ٢ ١ ٠

There are 2 typefaces which are used in all the Saudi Arbitration Center communications. They are as follows:

The Arabic font family of GE Thameen & HacenlinerXL. And the numbers always in Arabic corporate typeface. (for all Arabic print related usage, i.e. advertising, brochures, etc).

The English font family of TheSans B3 Light for normal and TheSans B4 Semilight for the Bold (for all English print related usage, i.e. advertising, brochures, etc).

The system Arabic and English fonts family of TheSans (for all digital communication, i.e. emails, Power Point presentations, website etc).

Note : Cards and letters should be handwritten when possible to provide a personal touch.

1.7.1. CORPORATE TYPOGRAPHY - ENGLISH

RECOMMENDED ENGLISH TYPEFACE
FOR SAUDI ARBITRATION CENTER

TheSans B3 Light - Body text

a b c d e f g h i j k l m n o p q r s t u v w x y z

0 1 2 3 4 5 6 7 8 9

TheSans B4 SemiLight - Heading

a b c d e f g h i j k l m n o p q r s t u v w x y z

0 1 2 3 4 5 6 7 8 9

The following font is to be used for all printed material from business to billboards. Bold to be used for headlines and regular for text. In specific applications such as stationery and advertising please refer to the relevant sections for guidelines.

For usage on stationery, advertising, collateral Bodycopy please refer to the relevant sections.

1.7.2. SYSTEM TYPOGRAPHY DIGITAL COMMUNICATION

RECOMMENDED DIGITAL COMMUNICATION
FOR SAUDI ARBITRATION CENTER

Arial (Body text)

أ ب ت ث ج ح خ د ذ ر ز س ش
ص ض ط ظ ع غ ف ق ك ل م ن ه و ي
٠ ١ ٢ ٣ ٤ ٥ ٦ ٧ ٨ ٩

Arial (Body text)

a b c d e f g h i j k l m n o p
q r s t u v w x y z
0 1 2 3 4 5 6 7 8 9

Arial is to be used for all on-line/digital communication, email, email signatures and PowerPoint presentations.

For email template and signature setup Please refer section 3.13.

For PowerPoint template setup Please refer section 3.14.

For Letterhead MS Word Arabic and English setup Please refer section 2.7. and 2.7.1.

1.7.3. TYPOGRAPHY USAGE - OFFSET PRINT

هذا نص تجريبي لاستخدام العرض فقط

هذا نص تجريبي لاستخدام العرض فقط، لا تقرأ الكلام المكتوب هذا نص تجريبي لاستخدام العرض فقط، هذا نص تجريبي
تجريبي لاستخدام العرض فقط، لا تقرأ الكلام المكتوب هذا نص تجريبي لاستخدام العرض فقط، هذا نص تجريبي
لاستخدام العرض فقط، لا تقرأ الكلام المكتوب هذا نص تجريبي لاستخدام العرض فقط

هذا نص تجريبي لاستخدام العرض فقط، لا تقرأ الكلام المكتوب هذا نص تجريبي لاستخدام العرض فقط، هذا نص
تجريبي لاستخدام العرض فقط، لا تقرأ الكلام المكتوب هذا نص تجريبي لاستخدام العرض فقط، هذا نص تجريبي
لاستخدام العرض فقط، لا تقرأ الكلام المكتوب هذا

WHAT IS DUMMY COPY TEXT?

Dummy Copytext or “Greeked text” refers to nonsensical passages of text which are used to demonstrate typography work. Greeked text is often in a foreign language (such as Greek, hence the name), or made up of nonexistent words, so that the viewers not be distracted by the textual content but can focus on the fonts and layout. The classic passages of “greeked text” were actually in Latin, specifically starting with the doggerel Lorem ipsum.

Where text is visible in a document people tend to focus on the textual content rather than upon overall presentation, so publishers use lorem ipsum when displaying a typeface or design in order to direct the focus to presentation. “Lorem ipsum” is also said to approximate a typical distribution of letters in English, which helps to shift the focus to presentation.

Arabic : An example of a headline for print usage is 16-20 points, GE Thameen Light, Saudi Arbitration Center green or Black. Bodycopy is 8.5 points, GE Thameen Light, with a leading 13, paragraph space 4mm, Black.

English : An example of a headline for print usage is 16-20 points, TheSans B3 Light Regular, Saudi Arbitration Center green & black. Bodycopy is 8.5 points, TheSans B3 Light Regular, with a leading of 13, paragraph space 5mm, Black. Address details on stationery should be 6 points (except A3 envelope), TheSans B3 Light Regular, Black.

1.7.4. TYPOGRAPHY USAGE- ONLINE & MS WORD

هذا نص تجريبي لاستخدام العرض فقط

هذا نص تجريبي لاستخدام العرض فقط، لا تقرأ الكلام المكتوب هذا نص تجريبي لاستخدام العرض فقط، هذا نص تجريبي لاستخدام العرض فقط، لا تقرأ الكلام المكتوب هذا نص تجريبي لاستخدام العرض فقط، هذا نص تجريبي لاستخدام العرض فقط، لا تقرأ الكلام المكتوب هذا نص تجريبي لاستخدام العرض فقط،

هذا نص تجريبي لاستخدام العرض فقط، لا تقرأ الكلام المكتوب هذا نص تجريبي لاستخدام العرض فقط، هذا نص تجريبي لاستخدام العرض فقط، لا تقرأ الكلام المكتوب هذا نص تجريبي لاستخدام العرض فقط، هذا نص تجريبي لاستخدام العرض فقط، لا تقرأ الكلام المكتوب هذا نص تجريبي لاستخدام العرض فقط، لا تقرأ الكلام المكتوب هذا

WHAT IS DUMMY COPY TEXT?

Dummy Copytext or “Greeked text” refers to nonsensical passages of text which are used to demonstrate typography work. Greeked text is often in a foreign language (such as Greek, hence the name), or made up of nonexistent words, so that the viewers not be distracted by the textual content but can focus on the fonts and layout. The classic passages of “greeked text” were actually in Latin, specifically starting with the doggerel Lorem ipsum.

Where text is visible in a document people tend to focus on the textual content rather than upon overall presentation, so publishers use lorem ipsum when displaying a typeface or design in order to direct the focus to presentation. “Lorem ipsum” is also said to approximate a typical distribution of letters in English, which helps to shift the focus to presentation.

-
- Arabic : An example of a headline for print usage is 16-20 points, GE Thameen Light, Saudi Arbitration Center Green or Black. Bodycopy is 8.5 points, GE Thameen Light, with a leading 13, paragraph space 4mm, Black.
- English : An example of a headline for print usage is 16-20 points, TheSans B3 Light Regular, Saudi Arbitration Center dark green & black. Bodycopy is 8.5 points, TheSans B3 Light Regular, with a leading of 13, paragraph space 5mm, Black. Address details on stationery should be 6 points (except A3 envelope), TheSans B3 Light Regular, Black.



2. STANDARD PAPER SIZES

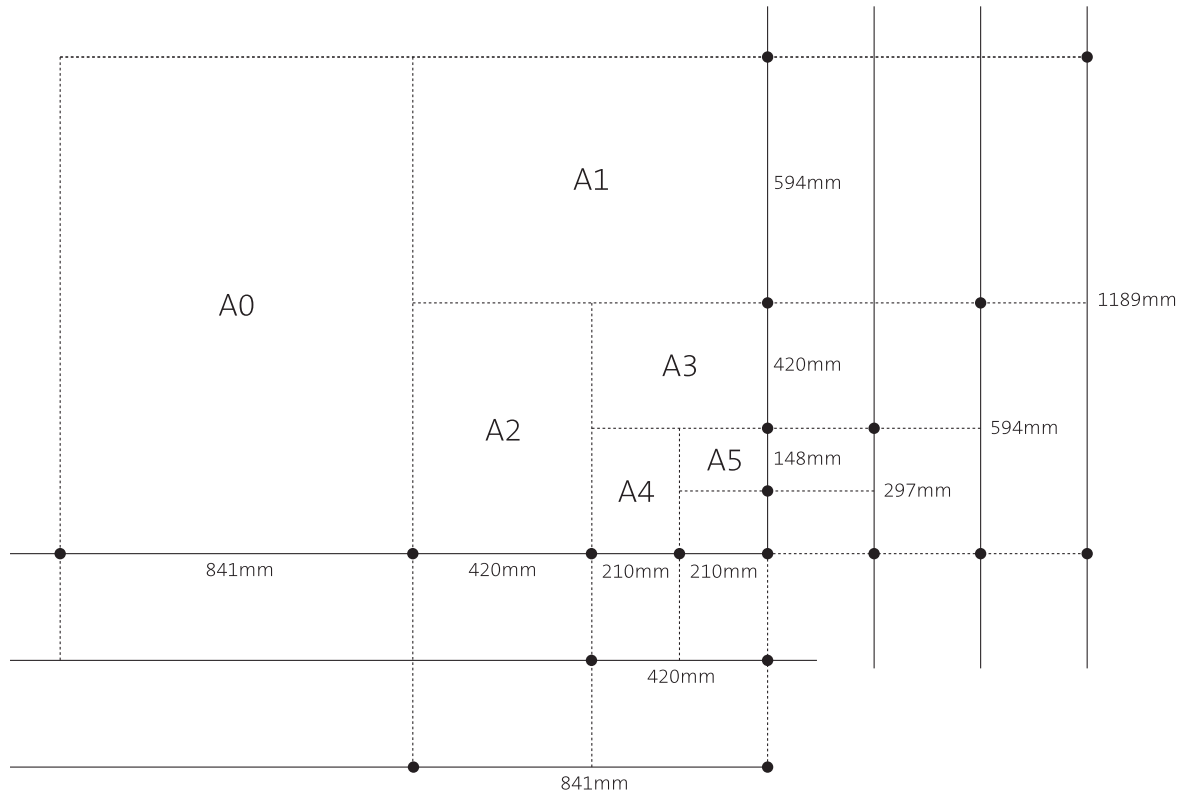

OTHER SIZES

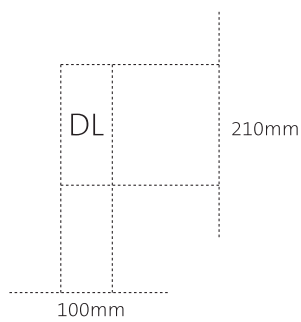

Size	mm	x	mm
A0	841	x	1189
A1	594	x	841
A2	420	x	594
A3	297	x	420
A4	210	x	297
A5	148	x	210

Size	mm	x	mm
A6	105	x	148
A7	74	x	105
A8	52	x	74
A9	37	x	52
A10	26	x	37

2.1. LETTERHEAD

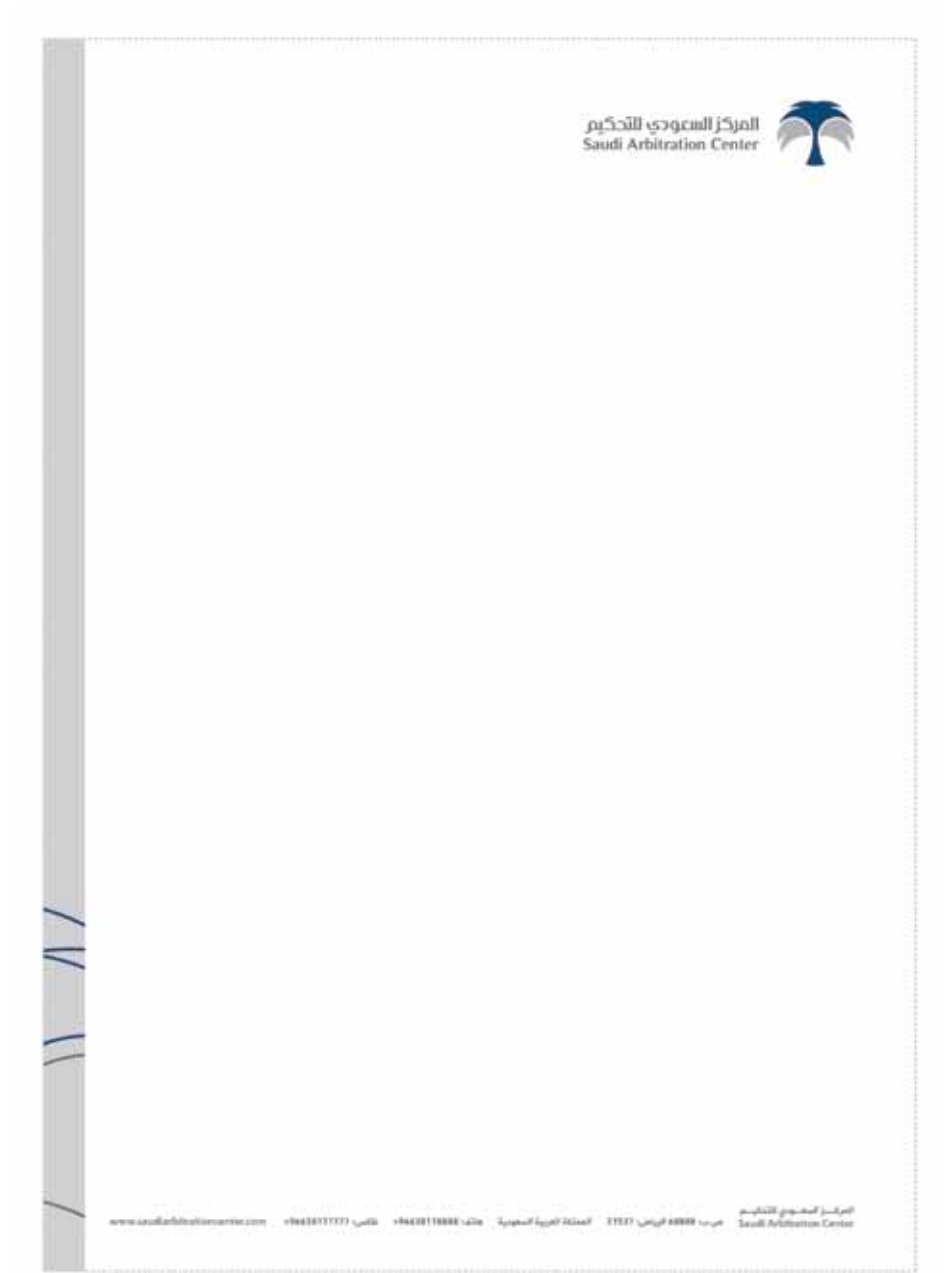

This is an example of the letterhead. For detailed specifications please see overleaf.

Note : Above specification is not actual size. Do not take measurement off this image.

2.1.1. LETTERHEAD

SAMPLE LETTERHEAD FRONT - TECHNICAL INFORMATION

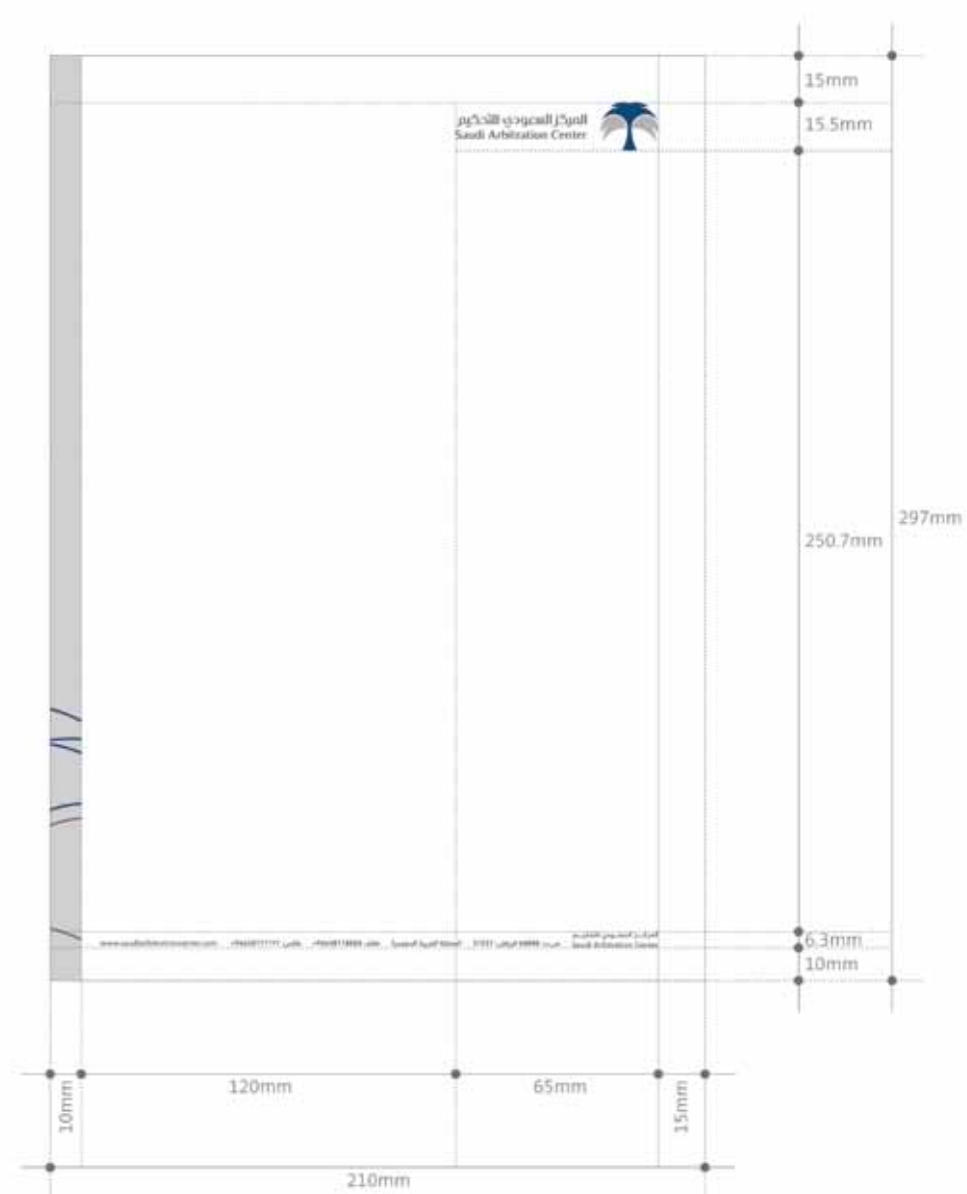

Size : The above example shows the assembly of a 210x297mm Letterhead. Top margin is 16mm and bottom 12mm, Logo 38x11.5mm.

Colors : Saudi Arbitration Center Color. Please refer section 1.6.

Fonts : Bottom text in English TheSans B3 Light , 8 points. Arabic GE Thameen , 8 points.

Note : Above specification is not actual size. Do not take measurement off this image.

2.1.2. LETTERHEAD MS WORD - ARABIC

SAMPLE LETTERHEAD - TECHNICAL INFORMATION

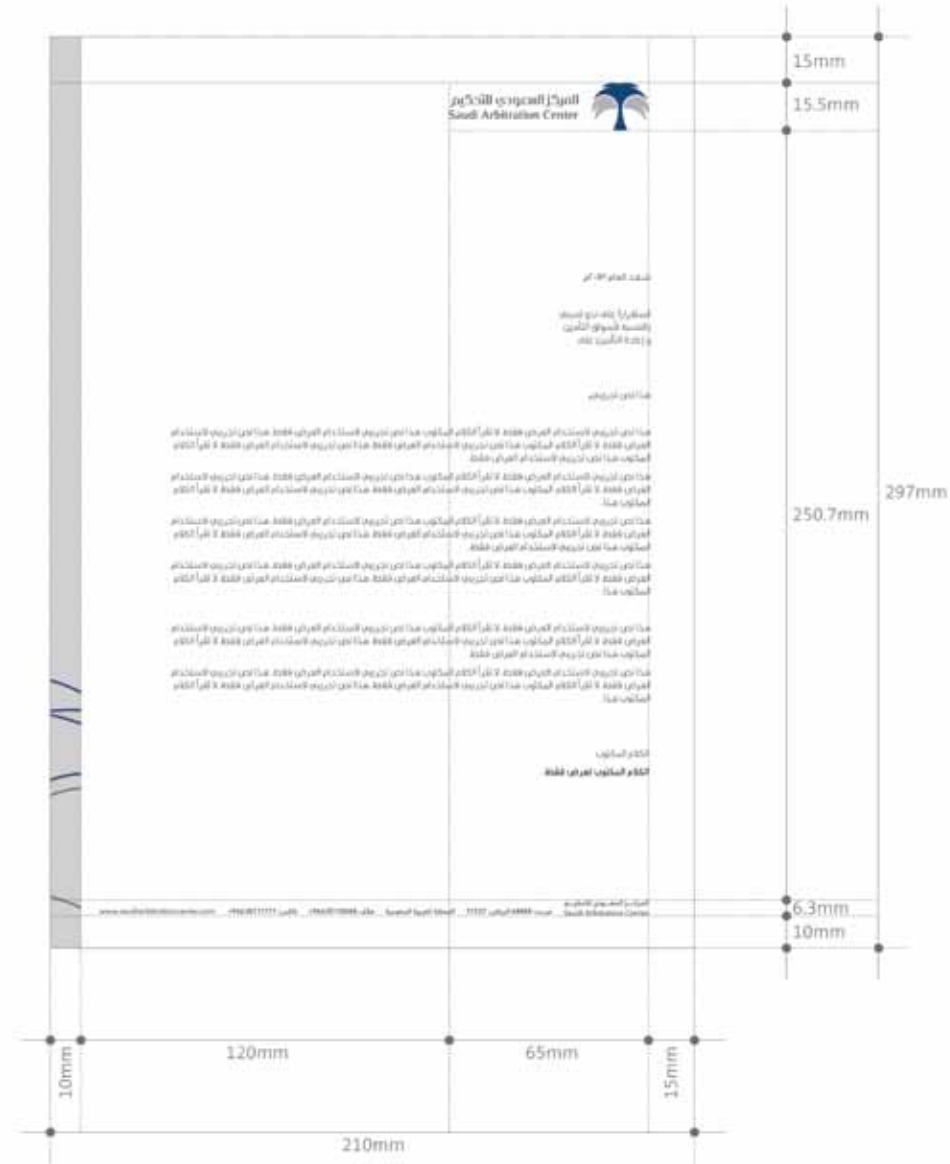

- Size : The above example shows the assembly of a 210x297mm Letterhead. Top margin is 16mm and bottom 12mm, Logo 38x11.5mm.
- Colors : Saudi Arbitration Center Color. All other text in black. Please refer section 1.6.
- Fonts : GE Thameen light Bodycopy 11 points, 15 leading, 5mm paragraph spacing. Double enter in after date, addressee detail, complimentary close. Heading 18 points GE Thameen .
- Note : Above specification is not actual size. Do not take measurement off this image. Header will contain the correct information. Do not add or remove any content from this.

2.1.3. LETTERHEAD MS WORD - ENGLISH

SAMPLE LETTERHEAD - TECHNICAL INFORMATION

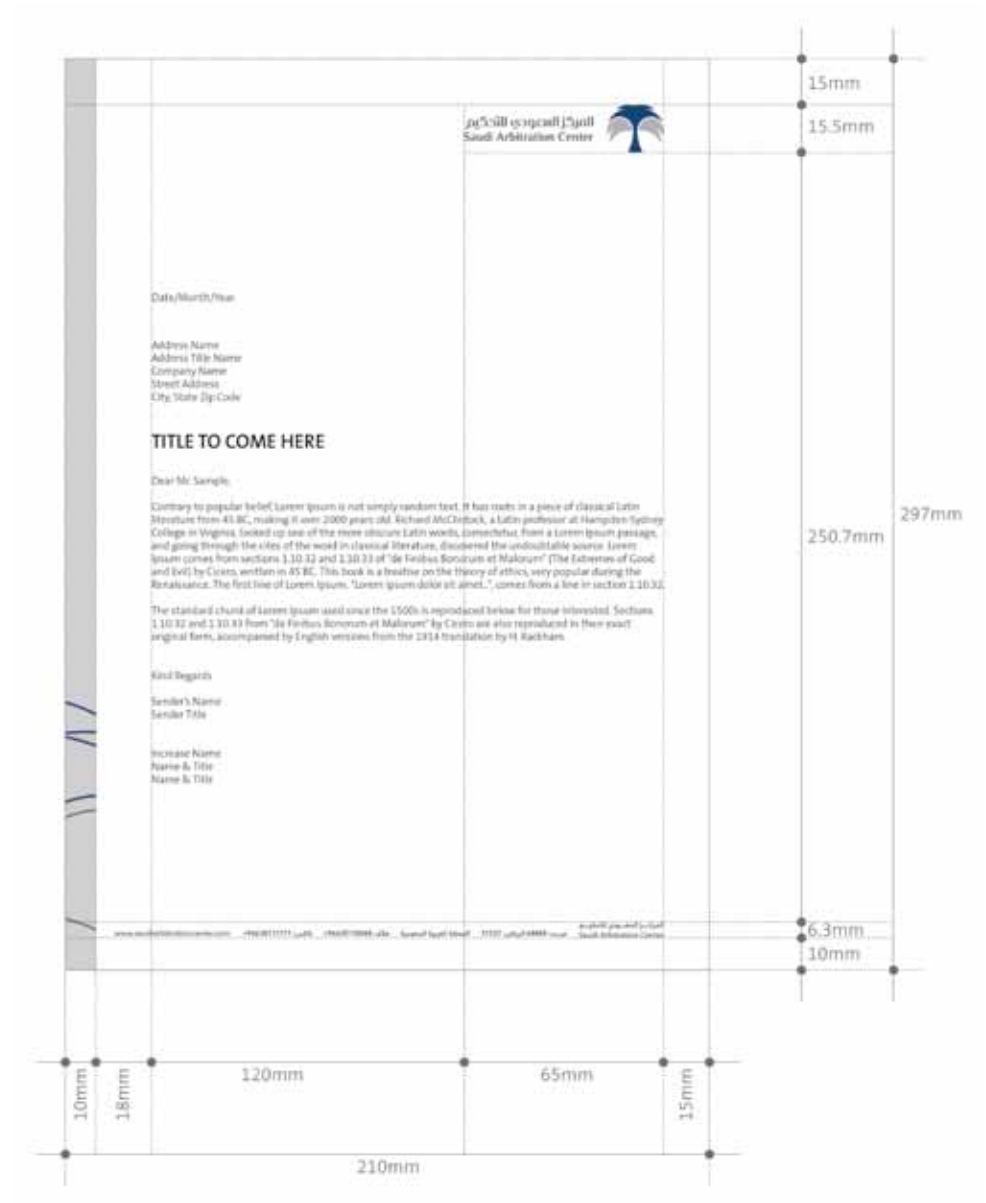

Size : The above example shows the assembly of a 210x297mm Letterhead. Top margin is 16mm and bottom 12mm, Logo 38x11.5mm.

Colors : Saudi Arbitration Center Color. All other text in black. Please refer section 1.6.

Fonts : TheSans B3 Light Bodycopy 11 points, 15 leading, 5mm paragraph spacing. Double enter in after date, addressee detail, complimentary close. Heading 18 points TheSans B3 Light .

Note : Above specification is not actual size. Do not take measurement off this image. Header will contain the correct information. Do not add or remove any content from this.

2.2. CONTINUATION SHEET



This is an example of the letterhead. For detailed specifications please see overleaf.

Note : Above specification is not actual size. Do not take measurement off this image.

2.2.1. CONTINUATION SHEET

SAMPLE CONTINUATION SHEET - TECHNICAL INFORMATION

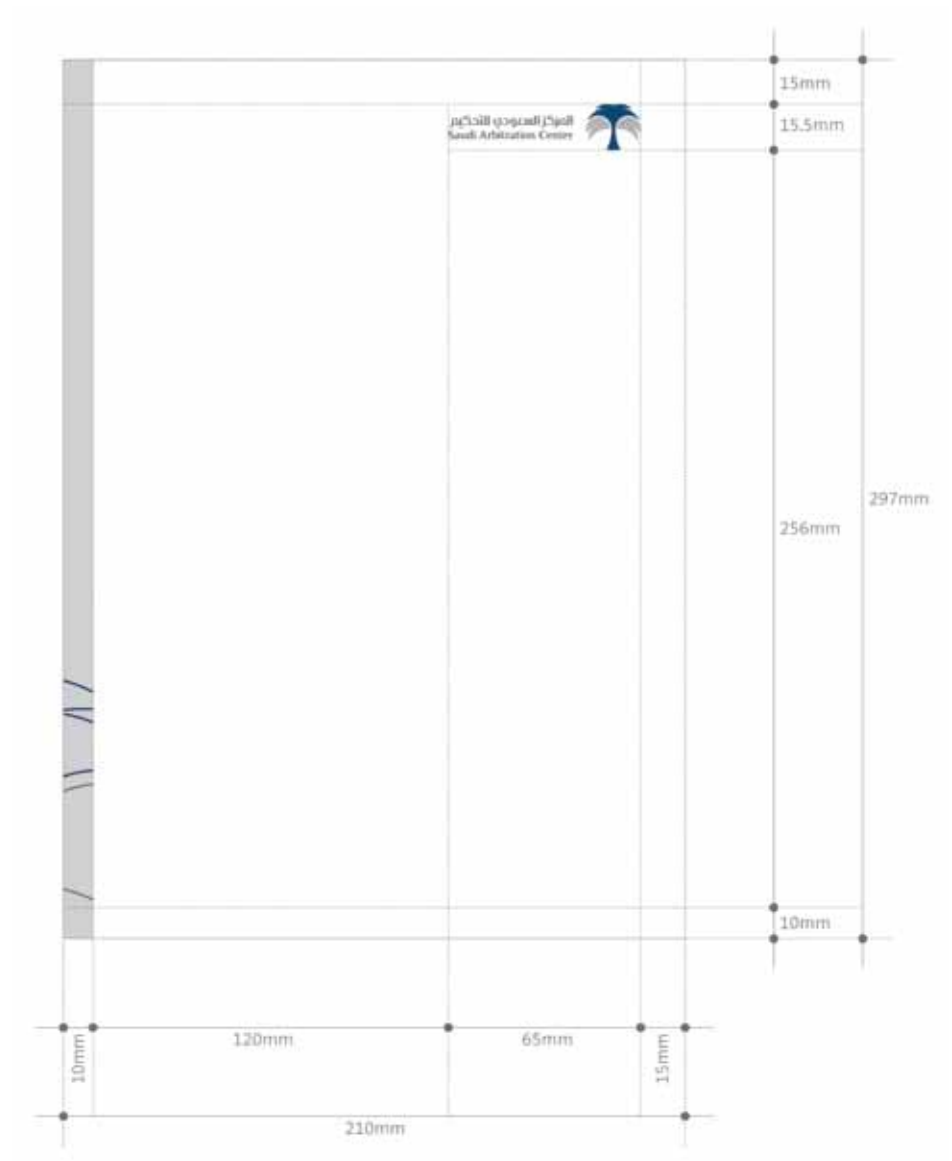

Size : The above example shows the assembly of a 210x297mm Continuation Sheet. Top margin is 15mm. Logo 40x20mm.

Colors : Saudi Arbitration Center Color. Please refer section 1.6.

Note : Above specification is not actual size. Do not take measurement off this image.

2.3. BUSINESS CARD



This is an example of the business card. For detailed specifications please see overleaf.

Note : Above specification is not actual size. Do not take measurement off this image.

2.3.1. BUSINESS CARD

SAMPLE BUSINESS CARD - TECHNICAL INFORMATION

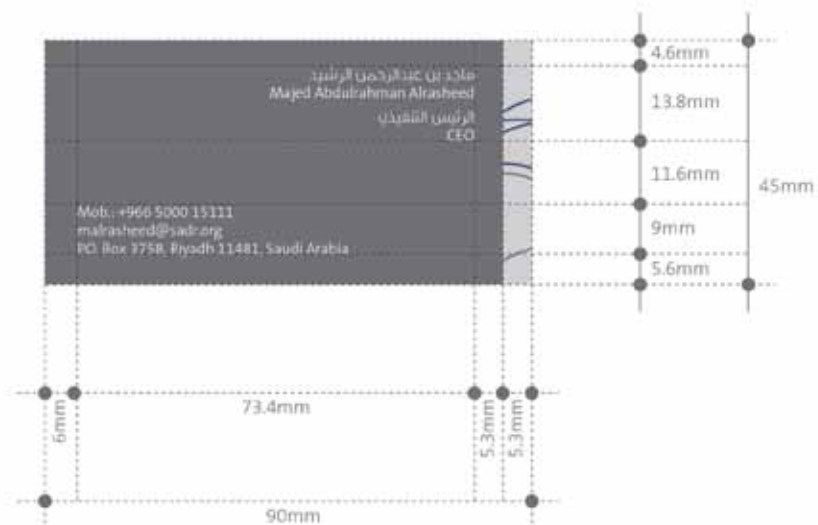
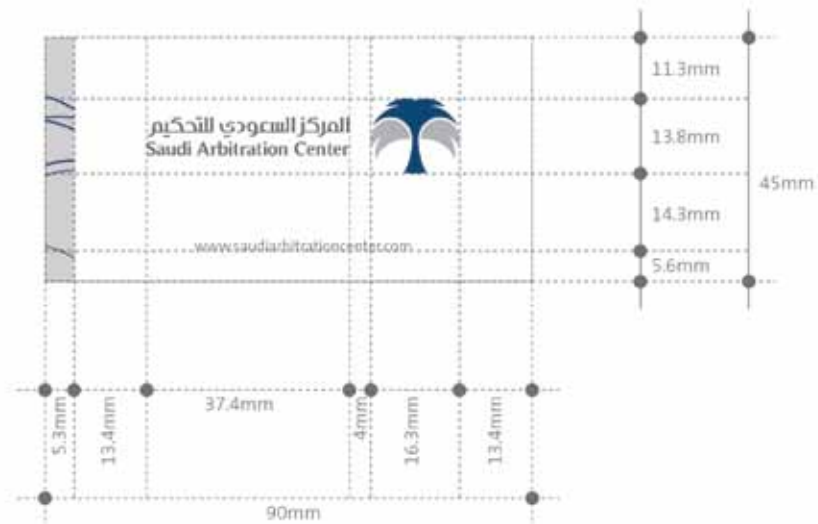

Size : The above example shows the assembly of a 90x45mm Business card. Top margin is 8mm and Left, Right and bottom 3mm, Logo 58x13.8mm.

Colors : Saudi Arbitration Center Color. Please refer section 1.6.

Fonts : Bottom text in English TheSans B3 Light , 8 points. Arabic GE Thameen , 8 points.

Note : Above specification is not actual size. Do not take measurement off this image.

2.4. IDENTITY CARD



This is an example of the Identity Card. For detailed specifications please see overleaf.

Note : Above specification is not actual size. Do not take measurement off this image.

2.4.1. IDENTITY CARD

SAMPLE ID CARD FRONT - TECHNICAL INFORMATION

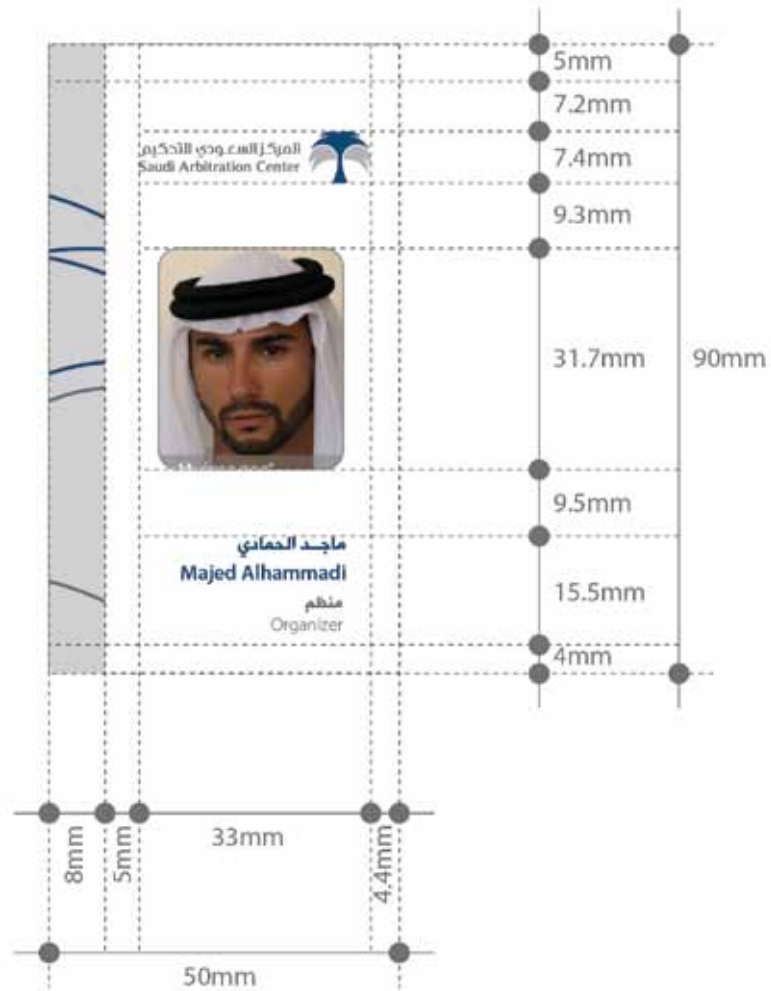

Size : The above example shows the assembly of a 90x50mm Identity Card. Top margin is 8mm and Left, Right and bottom 5mm, Logo 33x7.4mm.

Colors : Saudi Arbitration Center Color. Please refer section 1.6.

Fonts : Bottom text in English TheSans B3 Light , 8 points. Arabic GE Thameen , 8 points.

Note : Above specification is not actual size. Do not take measurement off this image.

2.4.2. IDENTITY CARD

SAMPLE ID CARD BACK - TECHNICAL INFORMATION

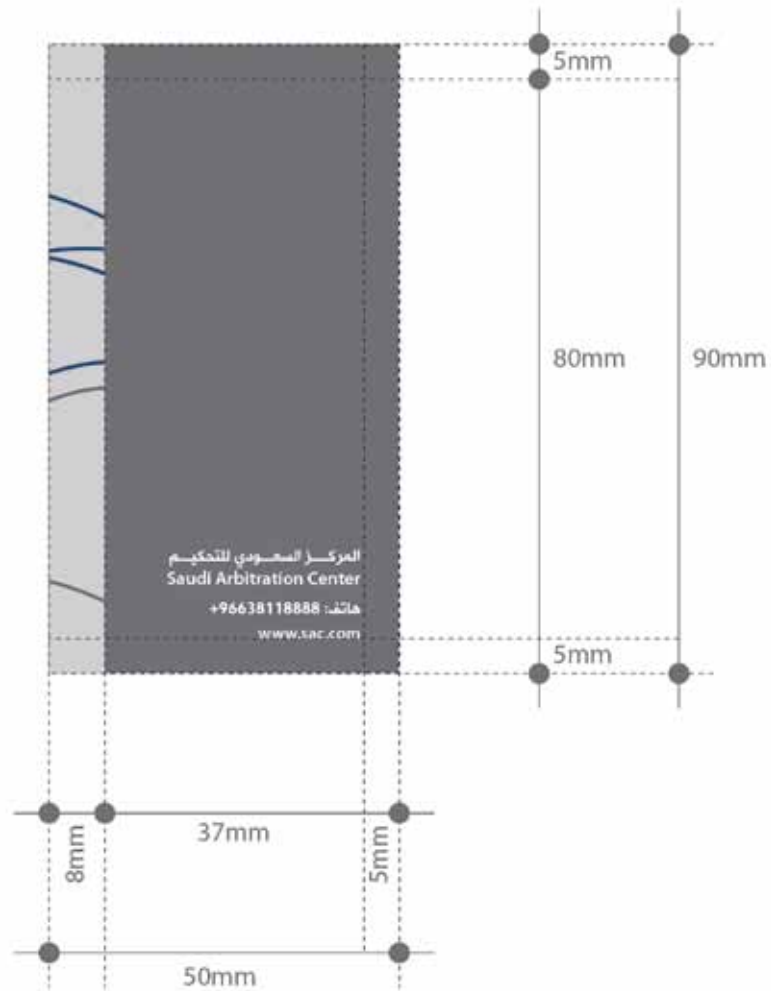

Size : The above example shows the assembly of a 90x50mm Identity Card. Top margin is 8mm and Left, Right and bottom 5mm.

Colors : Saudi Arbitration Center Color. Please refer section 1.6.

Fonts : Bottom text in English TheSans B3 Light , 8 points. Arabic GE Thameen , 8 points.

Note : Above specification is not actual size. Do not take measurement off this image.

2.5. ENVELOPE SPECIFICATION

ENVELOPE STYLES

Open Side

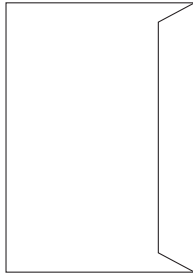

Open End



Pointed

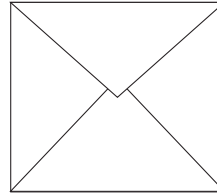

Commercial

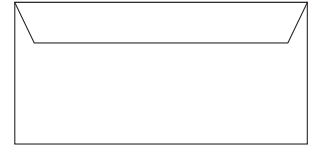

Wallet



Square



Window Envelopes

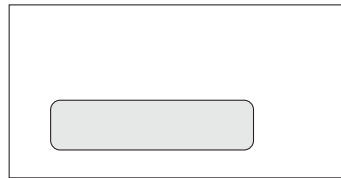

This is an example of the envelopes. For detailed specifications please see overleaf.

Note : Above specification is not actual size. Do not take measurement off this image.

2.6. DL ENVELOPE

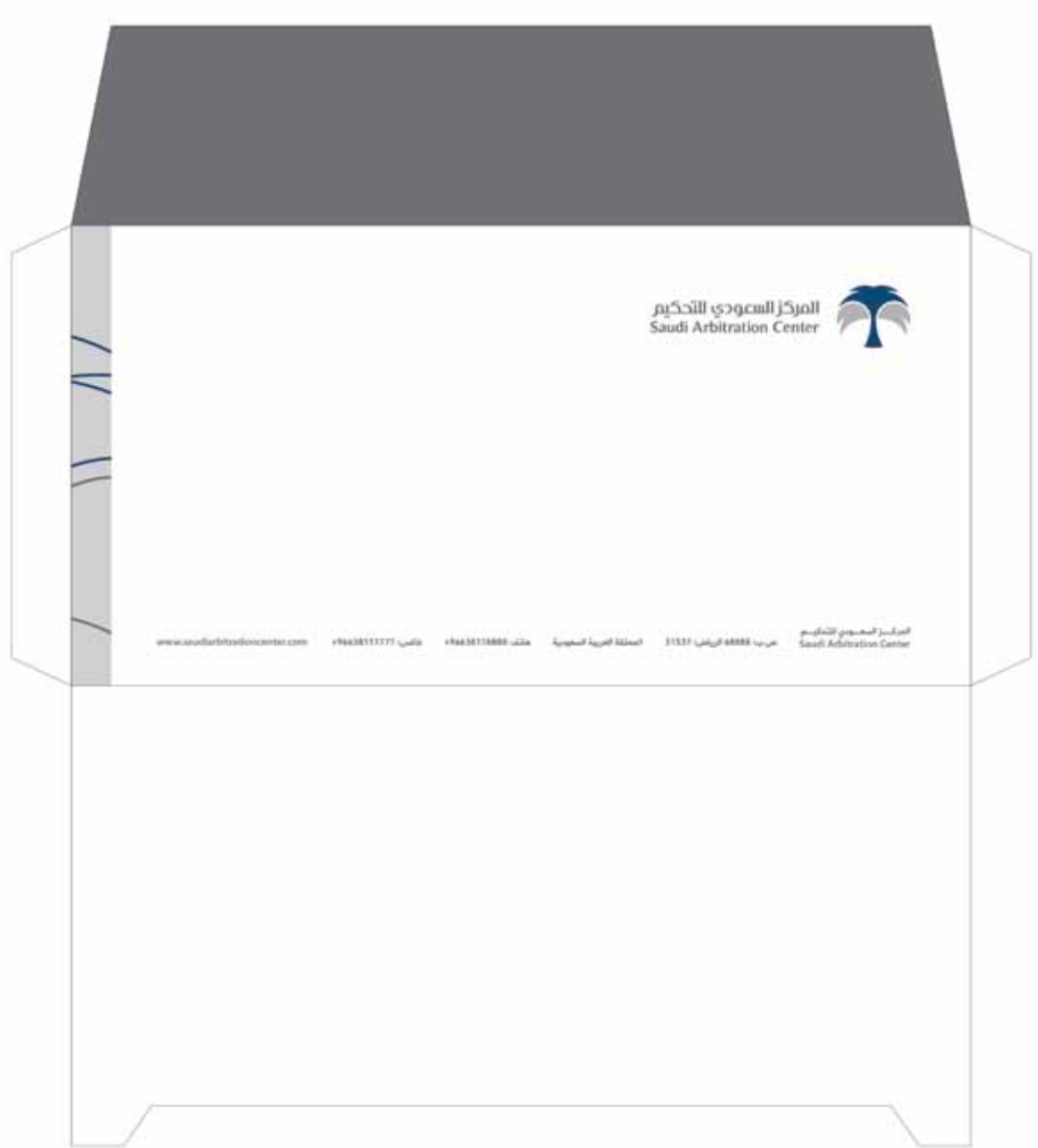

This is an example of the DL envelope. For detailed specifications please see overleaf.

Note : Above specification is not actual size. Do not take measurement off this image.

2.6.1. DL ENVELOPE

SAMPLE DL ENVELOPE - TECHNICAL INFORMATION

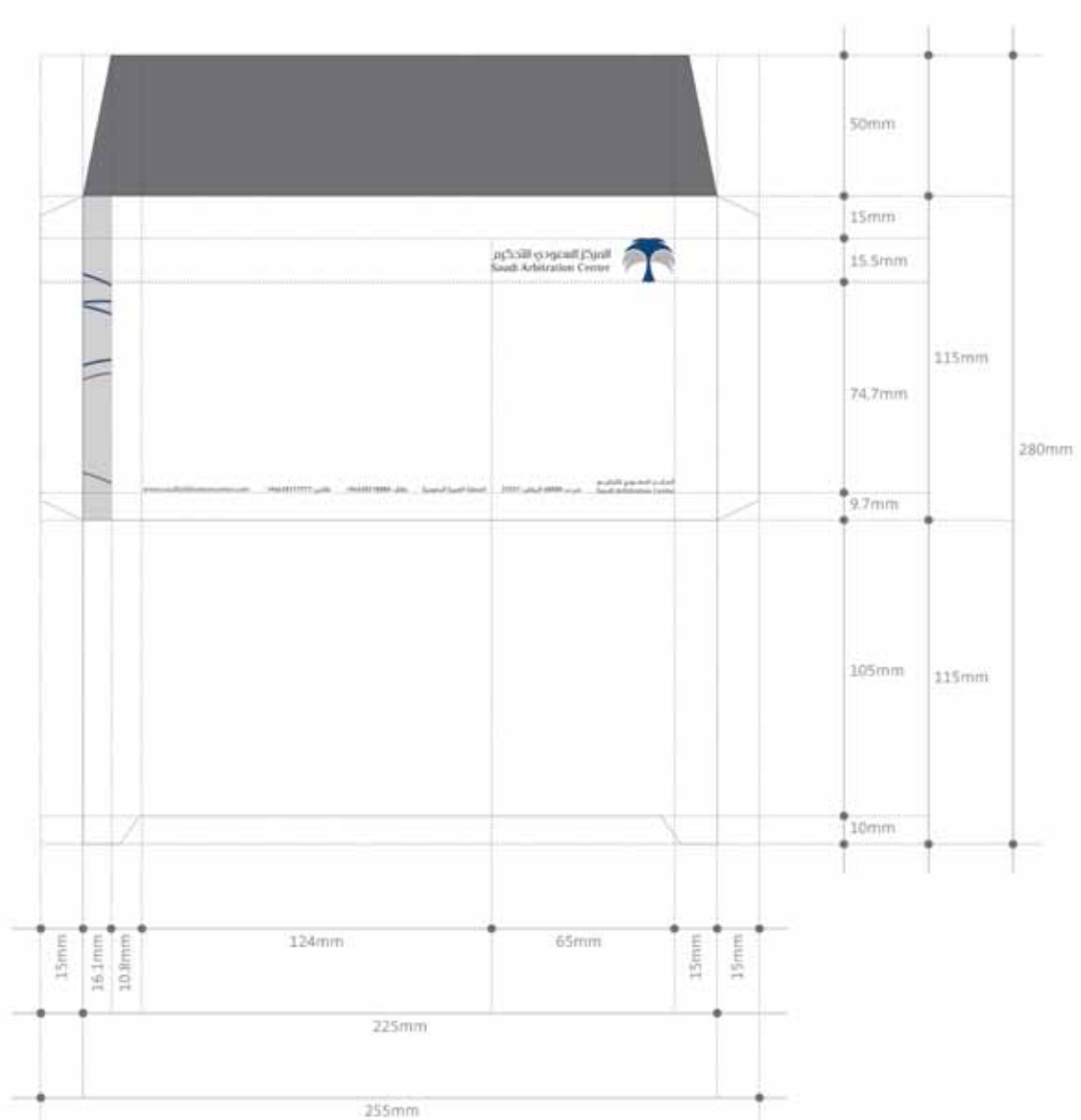

Size : The above example shows the assembly of a 225x115mm DL envelope. Open size 250x280mm. Logo 65x15.5mm.

Colors : Saudi Arbitration Center Color. Please refer section 1.6.

Fonts : Text in English TheSans B3 Light family. In Arabic GE Thameen family.

Note : Above specification is not actual size. Do not take measurement off this image.

2.7. A4 ENVELOPE

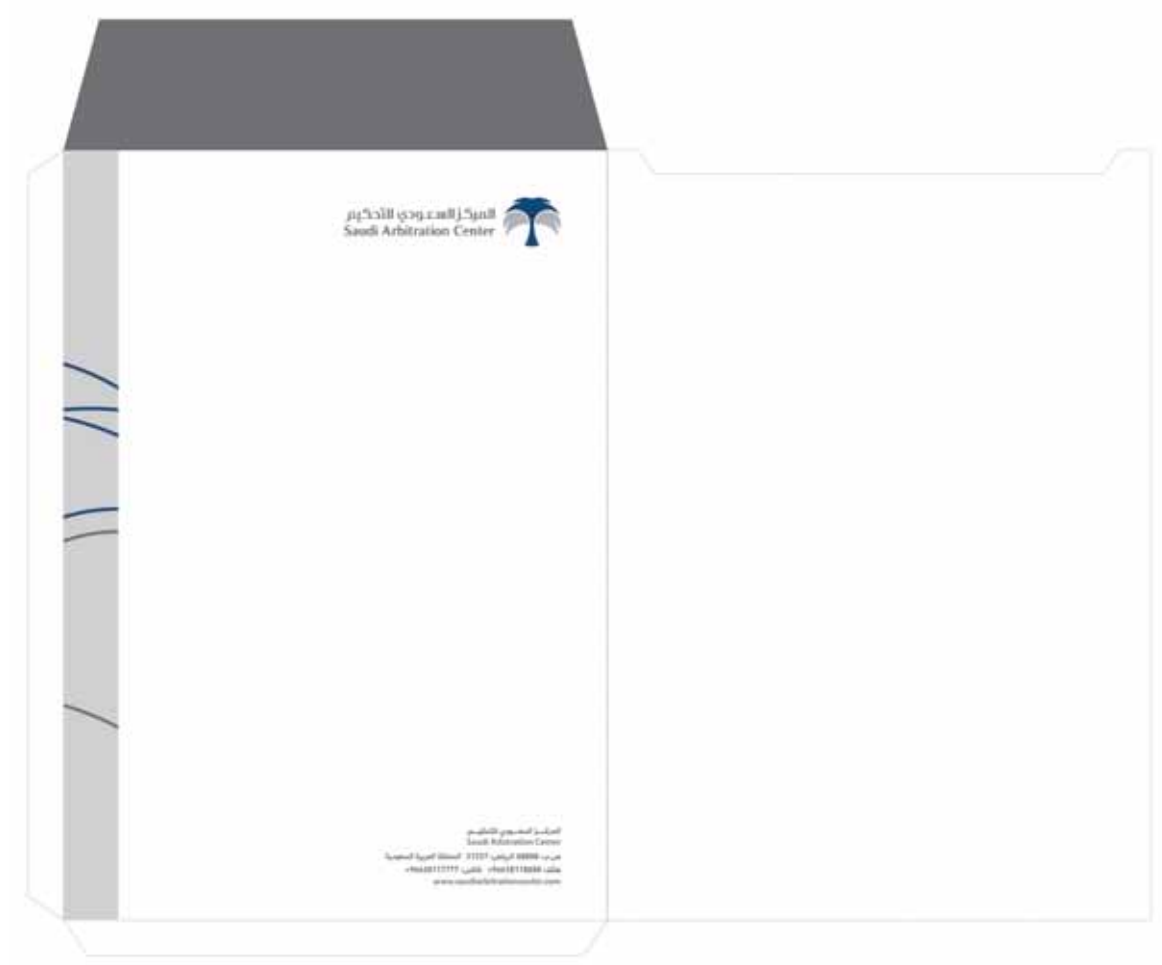

This is an example of the A4 envelope. For detailed specifications please see overleaf.

Note : Above specification is not actual size. Do not take measurement off this image.

2.7.1. A4 ENVELOPE

SAMPLE A4 ENVELOPE - TECHNICAL INFORMATION

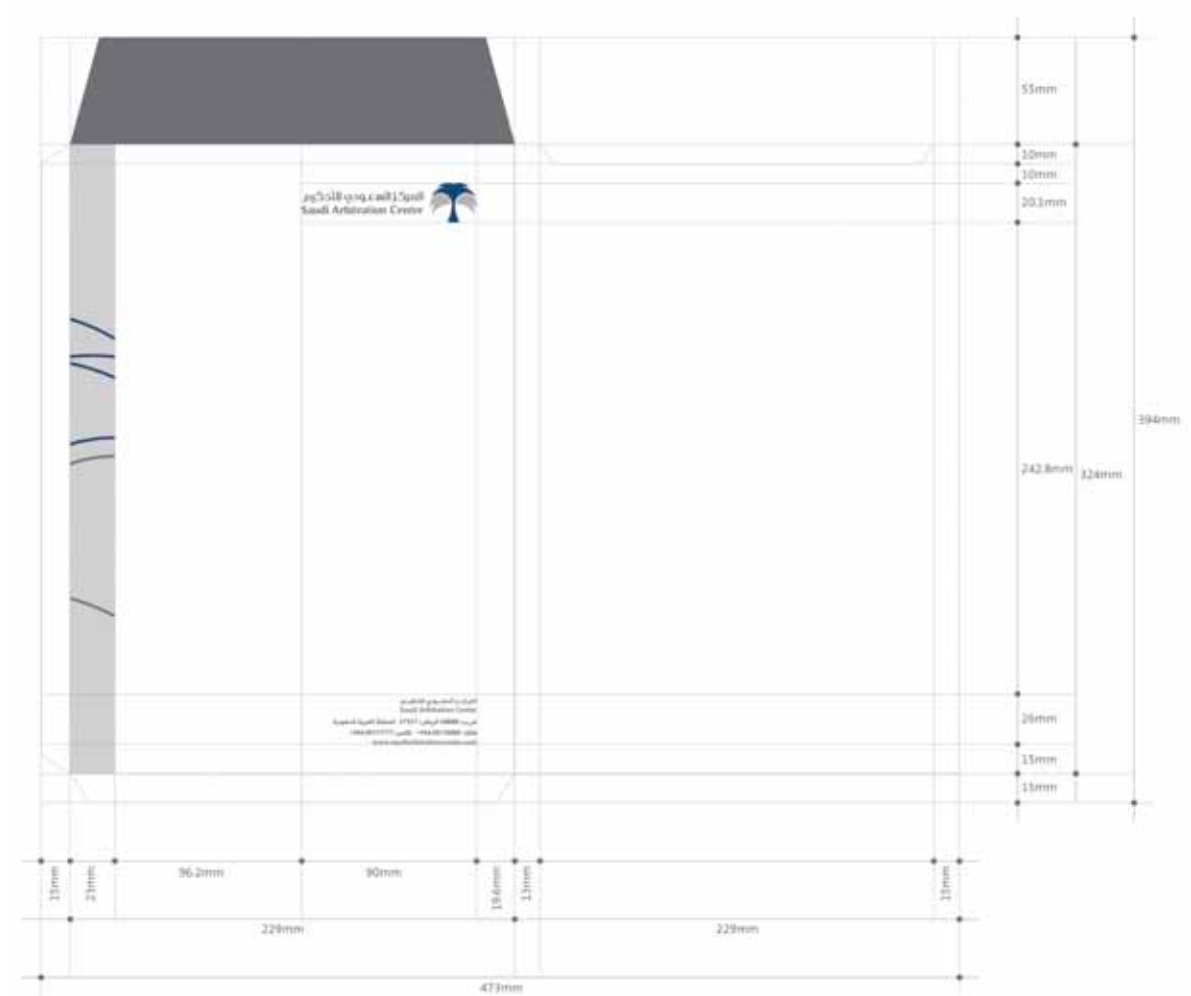

Size : The above example shows the assembly of a 229x324mm A4 envelope. Open size 473x400mm. Logo 90x20.1mm.

Colors : Saudi Arbitration Center Color. Please refer section 1.6.

Fonts : Text in English TheSans B3 Light family. In Arabic GE Thameen family.

Note : Above specification is not actual size. Do not take measurement off this image.

2.9. A4 FOLDER

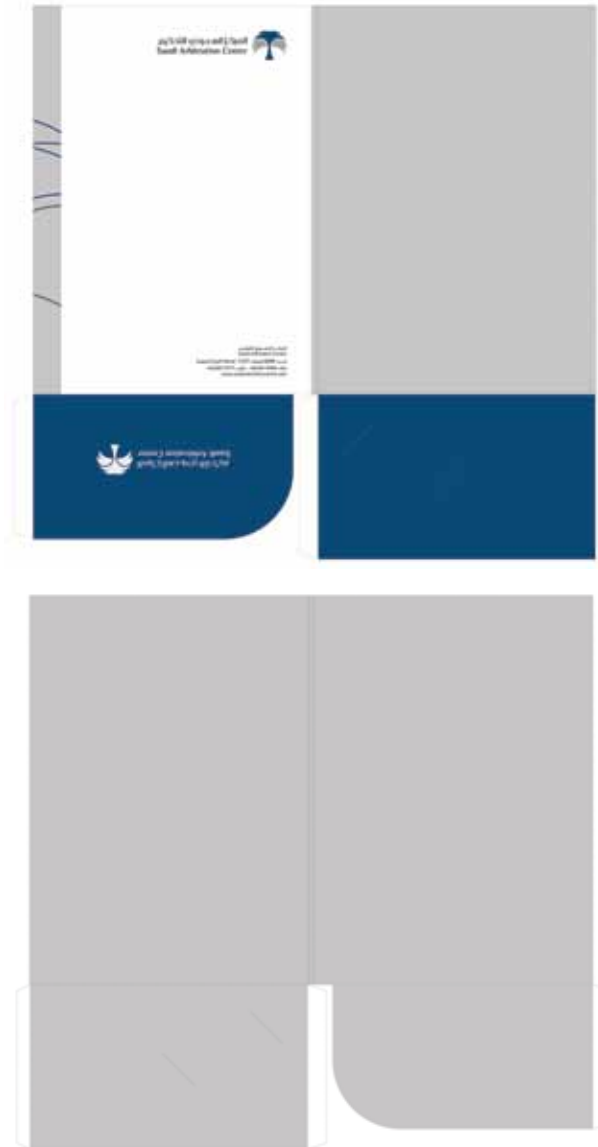

This is an example of the A4 Folder. For detailed specifications please see overleaf.

Note : Above specification is not actual size. Do not take measurement off this image.

2.9.1. A4 FOLDER

SAMPLE A4 FOLDER OUTSIDE - TECHNICAL INFORMATION

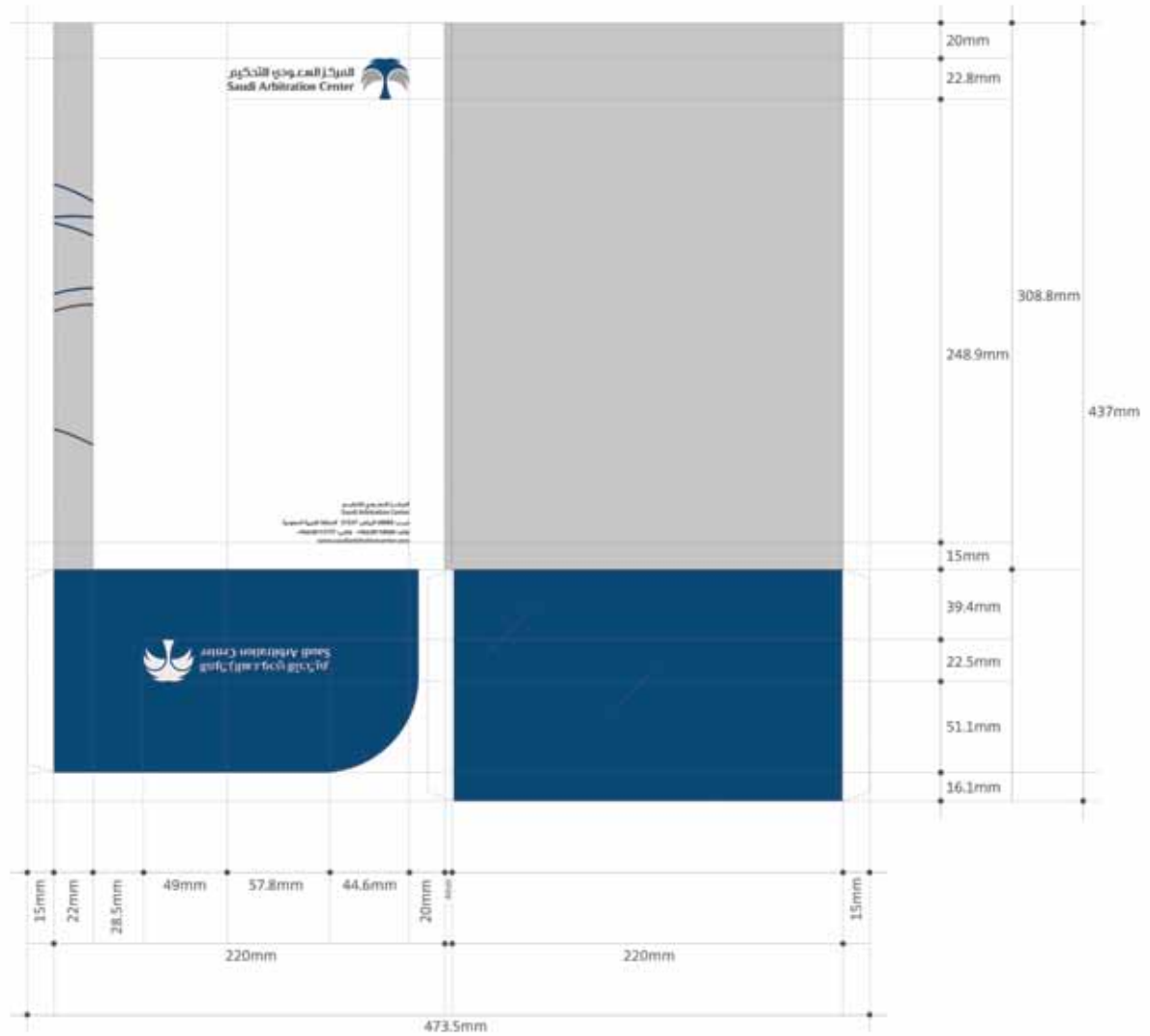

Size : The above example shows the assembly of a 225x310mm A4 folder. Open size 470x421mm. 5mm spine for folder and pouch. Logo 100x22.8mm. Pouch round corner.

Colors : Saudi Arbitration Center Color. Please refer section 1.6.

Fonts : TheSans B3 Light for english and GE Thameen for arabic for all text.

Finish : Matt lamination front side. For business card (90x50mm) placement on pouch left bottom with 20mm margin.

Note : Above specification is not actual size. Do not take measurement off this image.

2.9.1. A4 FOLDER

SAMPLE A4 FOLDER INSIDE - TECHNICAL INFORMATION

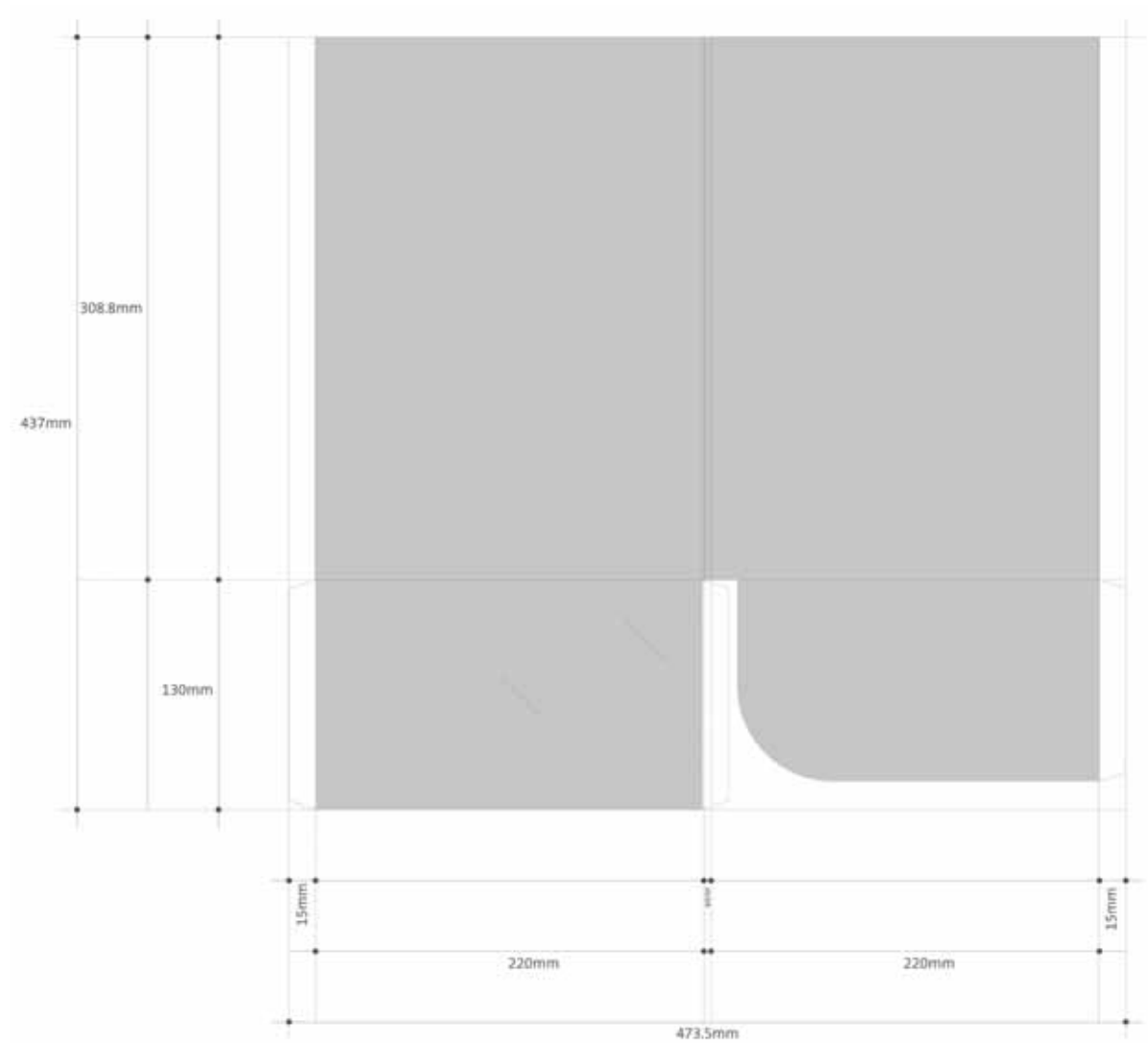

Size : The above example shows the assembly of a 225x310mm A4 folder. Open size 470x421mm. 5mm spine for folder and pouch.

Colors : Saudi Arbitration Center Color. Please refer section 1.6.

Fonts : TheSans B3 Light for english and GE Thameen for arabic for all text.

Finish : Matt lamination front side. For business card (90x50mm) placement on pouch left bottom with 20mm margin.

Note : Above specification is not actual size. Do not take measurement off this image.